

Proficiency Testing of Conducted Emission Measurements PTC(CE-9k-30M-III)

Firenze, 5th of March 2018

Rev. 1

C. Carobbi and A. Bonci, University of Florence, Firenze, Italy

M. Cati, Powersoft S.p.A., Firenze, Italy

C. Panconi, Elettroingegneria, Pistoia, Italy

M. Borsero, G. Vizio, INRIM, Torino, Italy

Travelling Sample for the 9 kHz to 30 MHz frequency range (Conducted Emission)

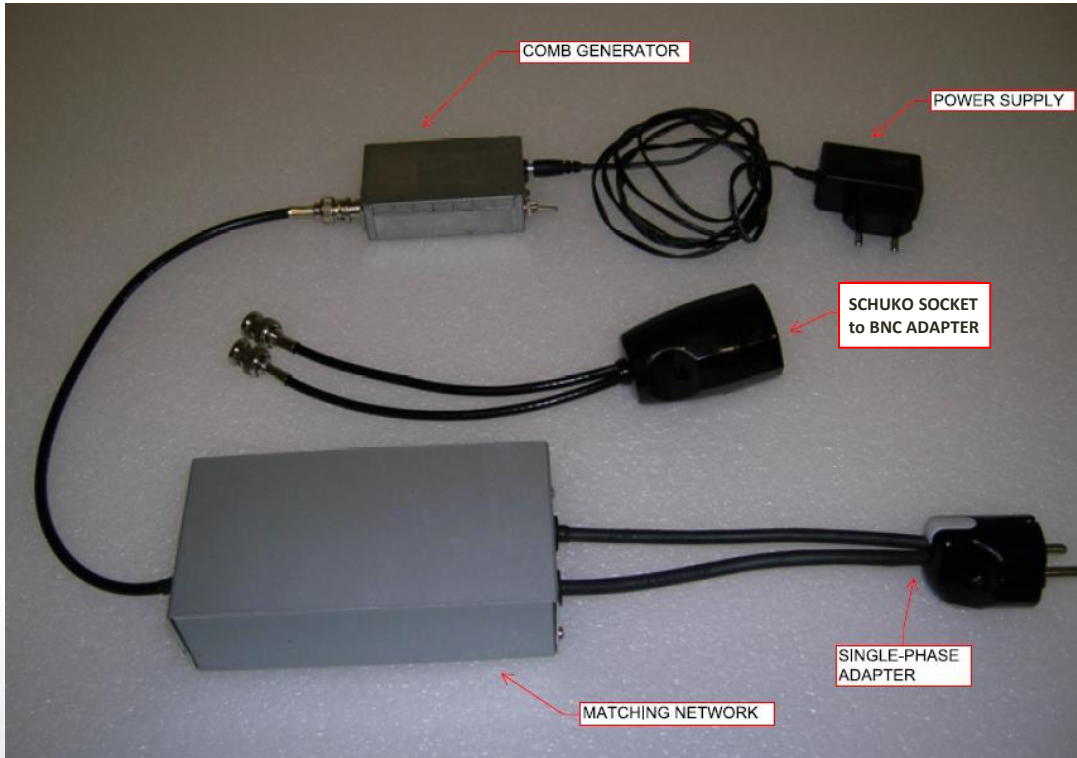

General information

- Number of participants: 18
- Start date: May 2017
- Stop date: January 2018 (one lab carried out measurements two months after the stop date and its results are taken into account by this report).
- Issues faced: None
- Scheme of the proficiency test PTC(CE-9k-30M-III):
<https://www.dinfo.unifi.it/vp-436-schemi-prove-valutative.html>

Measurement procedure

- Voltage measurement by using the AMN and EMI receiver is preceded by a preliminary measurement of the voltage that the Sample applies at the input of an oscilloscope (two channels, at least 100 MHz bandwidth, $1\text{ M}\Omega \parallel (< 30\text{ pF})$ input impedance).
- Measurement by using the AMN and EMI receiver are performed according to §7.4.2 of EN 55016-2-1:2009, and next amendments, by using a V-type Artificial Mains Network (AMN).
- The Laboratory measures the amplitude of ten (10) harmonics selected by the Coordinator in the frequency range between 9 kHz and 30 MHz (i.e. covering both band A and band B). The disturbance injected by the Sample on both line and neutral conductors is measured. A total number of twenty (20) measurements (two conductors times ten frequencies) is reported to the Coordinator by the Laboratory.

Sequence of operations

- Connect the Sample to the EUT port of the AMN: the AMN is not powered when the Sample is connected to the AMN;
- Power up the AMN;
- Power up the Sample by using the power supply provided by the Coordinator;
- Select the spacing of the harmonics generated by the Sample through the switch S;
- Measure the amplitude of the ten harmonics selected by the Coordinator by using the EMI receiver set with average detector;
- Connect the EMI receiver first to the line and then to the neutral conductor at each frequency (twenty measurements total);
- Power off the AMN;
- Power off the Sample;
- Disconnect the Sample from the AMN.

Measurement result

- The measurement result provided by the Laboratory consists of:
 - The estimate x , expressed in dB(μ V), of the amplitude of the selected harmonics, measured both line-to-ground (x_{line}) and neutral-to-ground ($x_{neutral}$);
 - The expanded uncertainty of the estimate x , U_{lab} , expressed in dB and obtained multiplying the combined standard uncertainty by the coverage factor $k = 2$ (which corresponds to a coverage probability of about 95 % assuming normal distribution).

Reference values

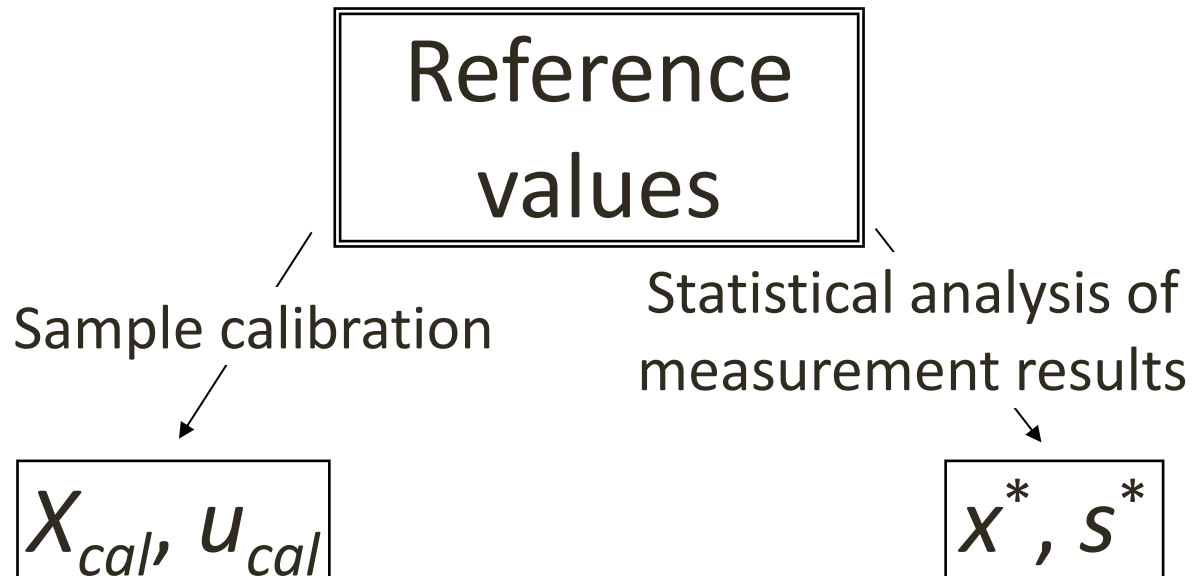

Sample calibration (CE)

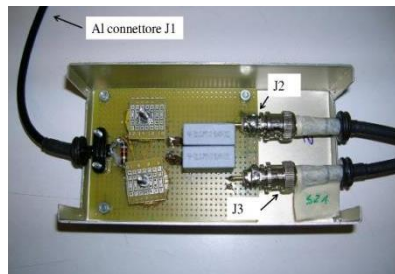
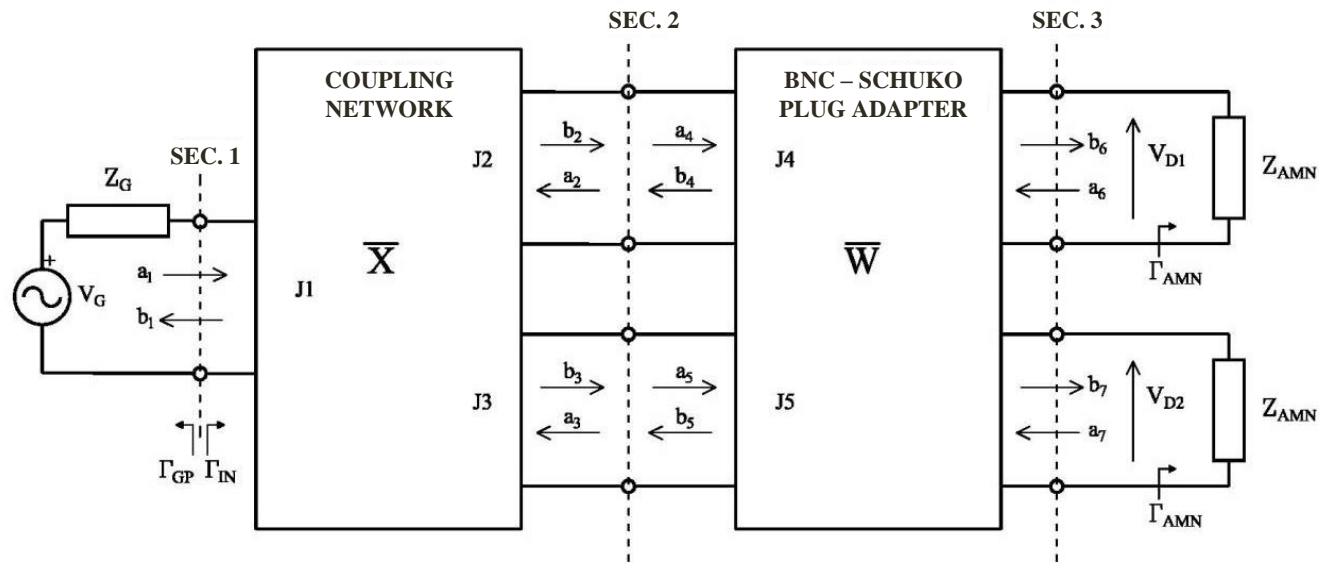

The **circuit model of the coupling network and adapter is validated** through vector network measurements.

AMN voltage is predicted by using the circuit model and source calibration.

Statistical (robust) analysis

$x_1, x_2, \dots, x_i, \dots, x_p$ } Raw data (p participants)

$x^* = \text{median of } x_i \quad (i = 1, 2, \dots, p)$

$s^* = 1,483 \text{ median of } |x_i - x^*| \quad (i = 1, 2, \dots, p)$

} Initial reference value

$\delta = 1,5s^*$

$x_i^* = \begin{cases} x^* - \delta, & \text{if } x_i < x^* - \delta \\ x^* + \delta, & \text{if } x_i > x^* + \delta \\ x_i, & \text{otherwise} \end{cases}$

} Transformed set of data

$x^* = \sum x_i^* / p$

$s^* = 1,134 \sqrt{\sum (x_i^* - x^*)^2 / (p - 1)}$

} New reference value
(iterative algorithm)



Performance statistic ζ (Participant)

- Performance statistic ζ (clause 7.7 of ISO 13528) that the Coordinator applies to the Participant providing the measurement result x_i with standard uncertainty u_{x_i}

$$\zeta_i = \frac{x_i - X}{\sqrt{u_{x_i}^2 + u_X^2}} \quad \left\{ \begin{array}{l} X = X_{cal}, u_X = u_{cal} \\ X = x^*, u_X = \frac{1,25 \cdot s^*}{\sqrt{p}} \end{array} \right.$$

$$\left\{ \begin{array}{l} 2 < |\zeta_i| < 3 \Rightarrow \text{warning} \\ 3 < |\zeta_i| \Rightarrow \text{action} \end{array} \right.$$

Performance statistic z' (Coordinator)

- Performance statistic z' (clause 5.7 of ISO 13528) that the Coordinator applies as self-check

$$z' = \frac{X_{cal} - x^*}{\sqrt{u_{cal}^2 + \left(\frac{1,25 \cdot s^*}{\sqrt{p}}\right)^2}} \quad \begin{cases} 2 < |z'| < 3 \Rightarrow \textit{warning} \\ 3 < |z'| \Rightarrow \textit{action} \end{cases}$$

Results

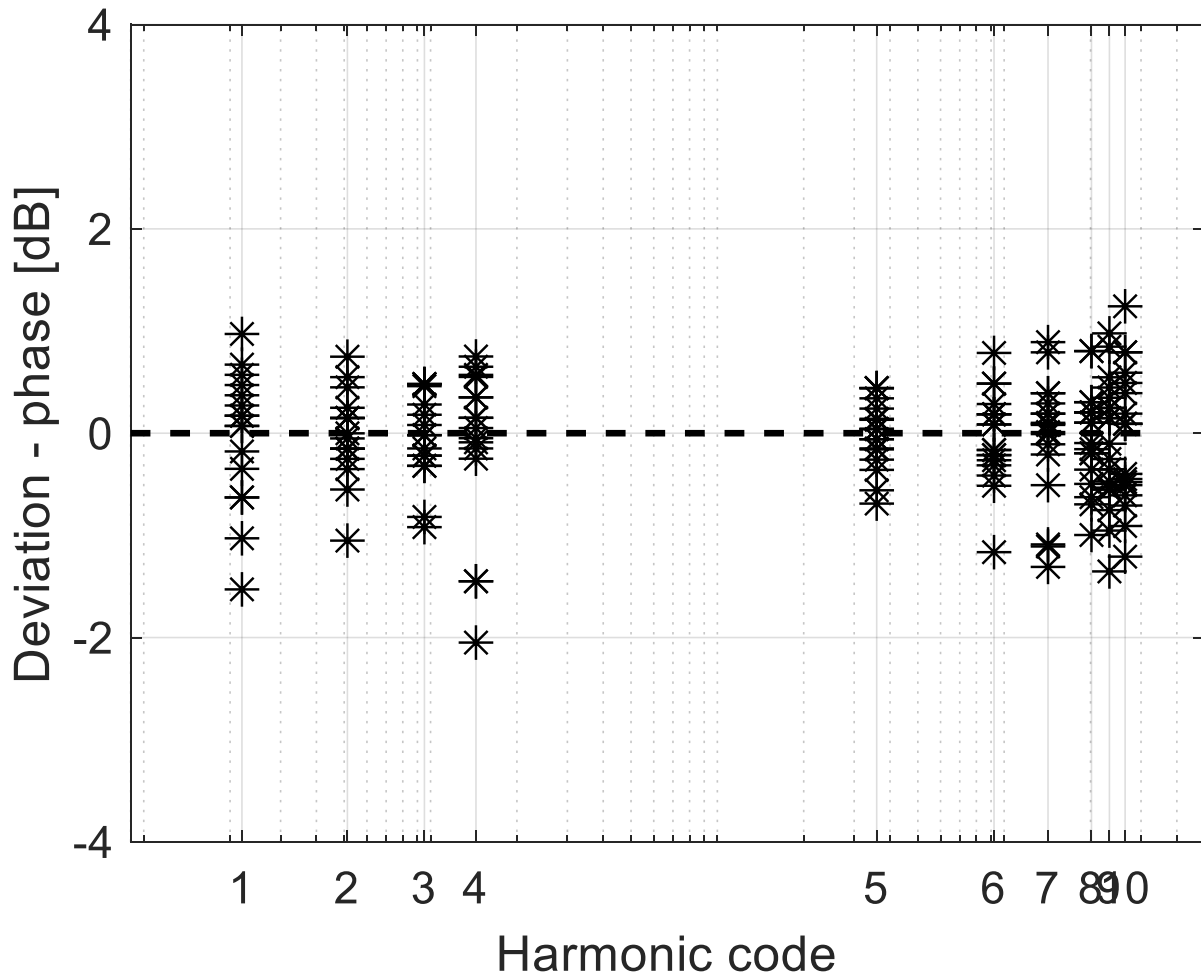

1 = 22k - 2 = 51k - 3 = 95k - 4 = 144k - 5 = 3,6M - 6 = 9M - 7 = 14M - 8 = 20M - 9 = 23M - 10 = 26M

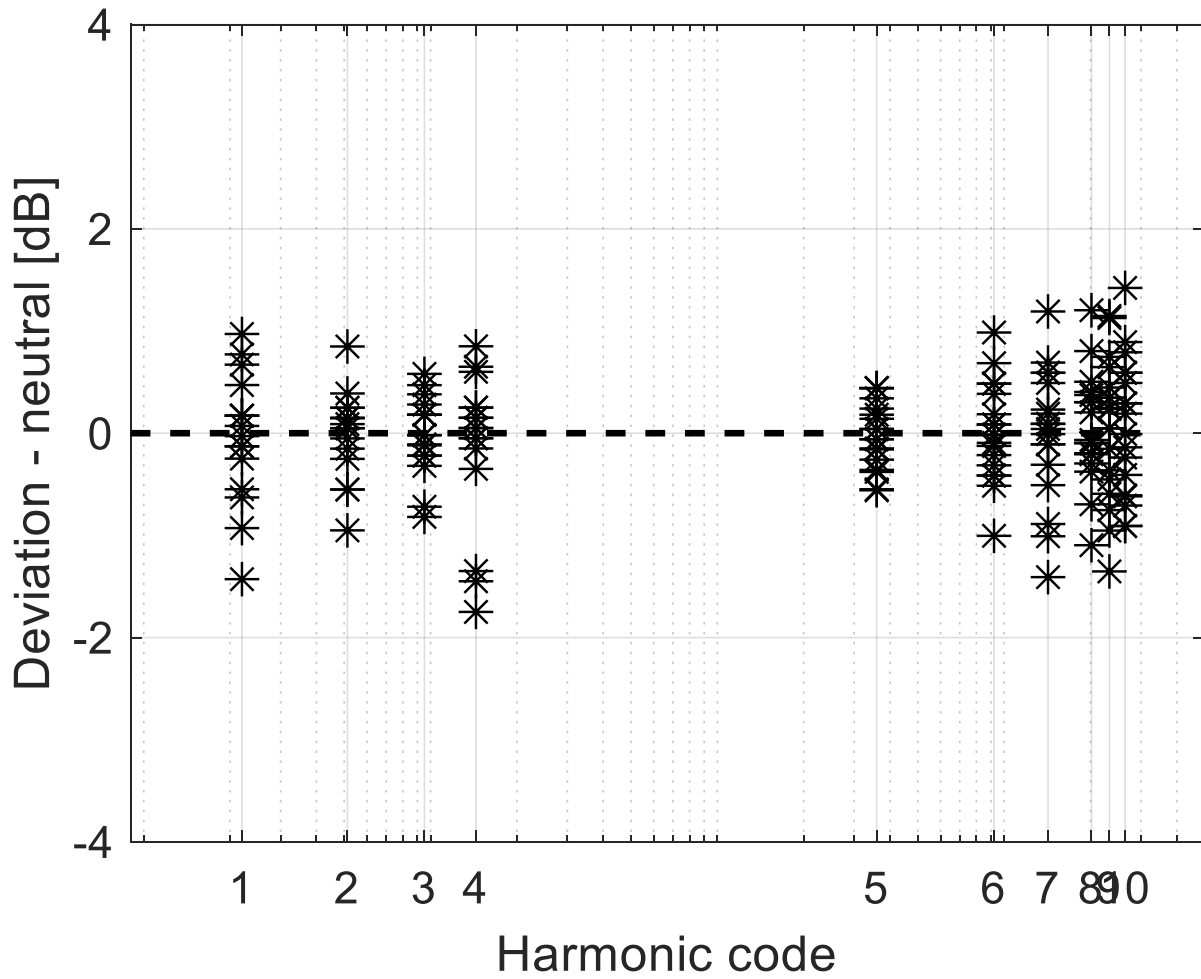

1 = 22k - 2 = 51k - 3 = 95k - 4 = 144k - 5 = 3,6M - 6 = 9M - 7 = 14M - 8 = 20M - 9 = 23M - 10 = 26M

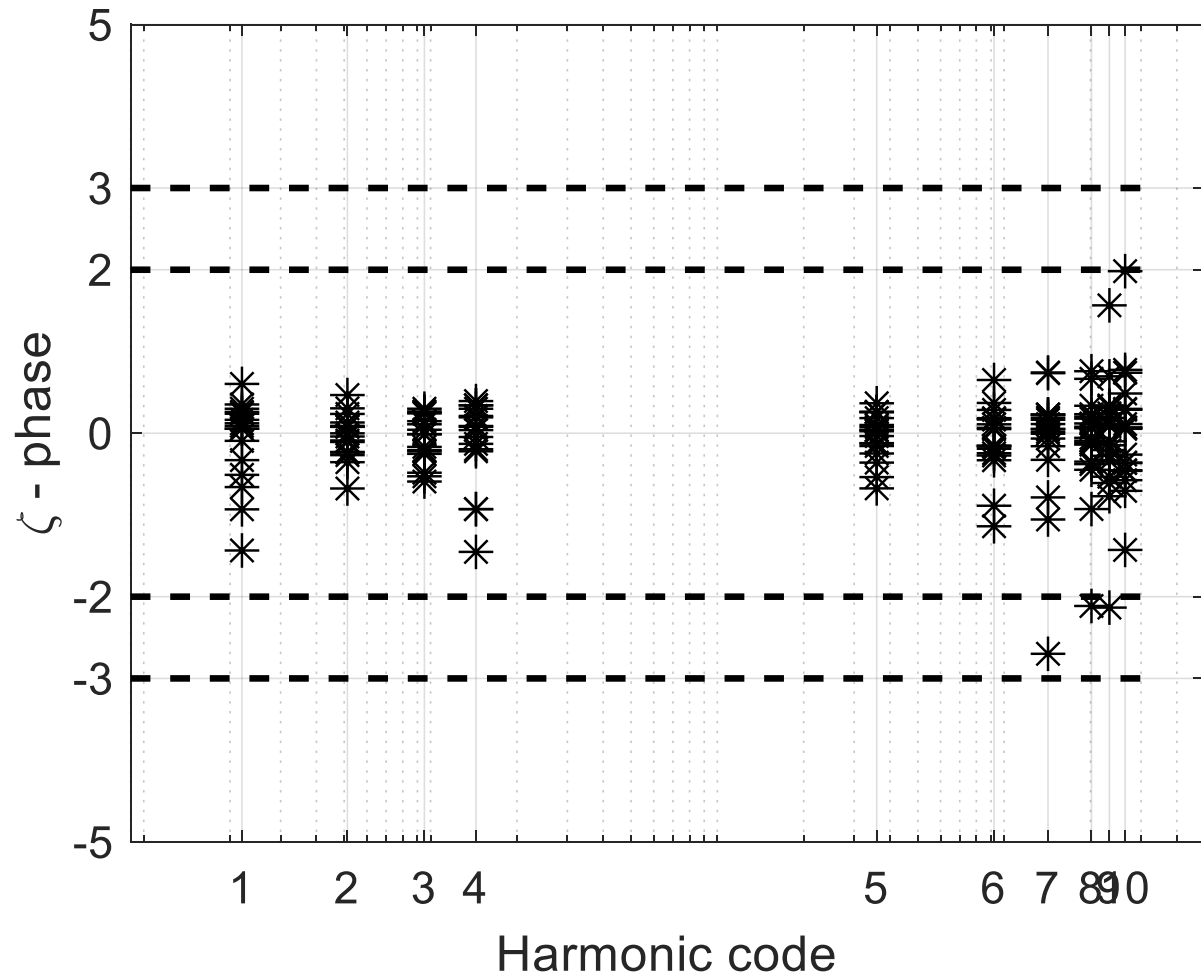

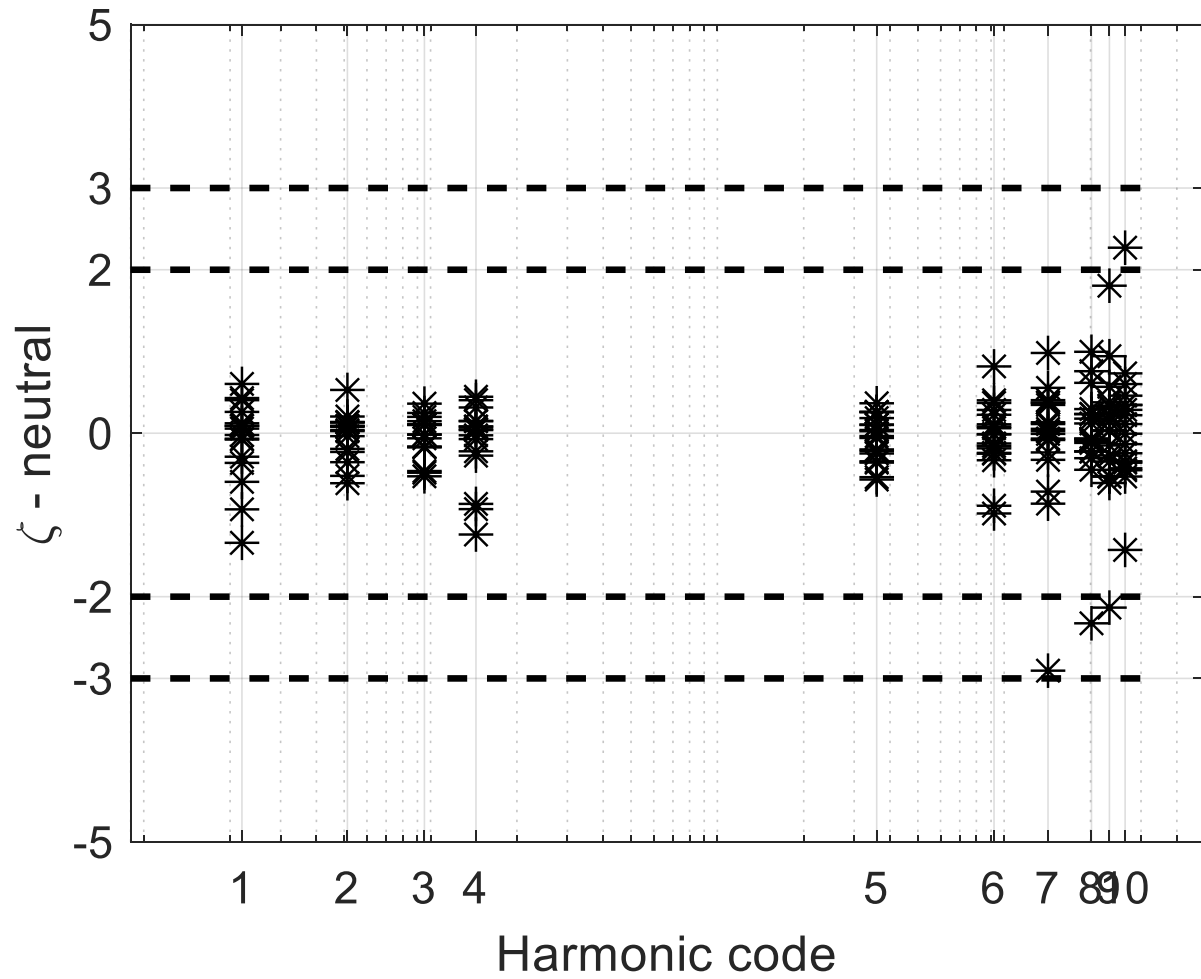

1 = 22k - 2 = 51k - 3 = 95k - 4 = 144k - 5 = 3,6M - 6 = 9M - 7 = 14M - 8 = 20M - 9 = 23M - 10 = 26M

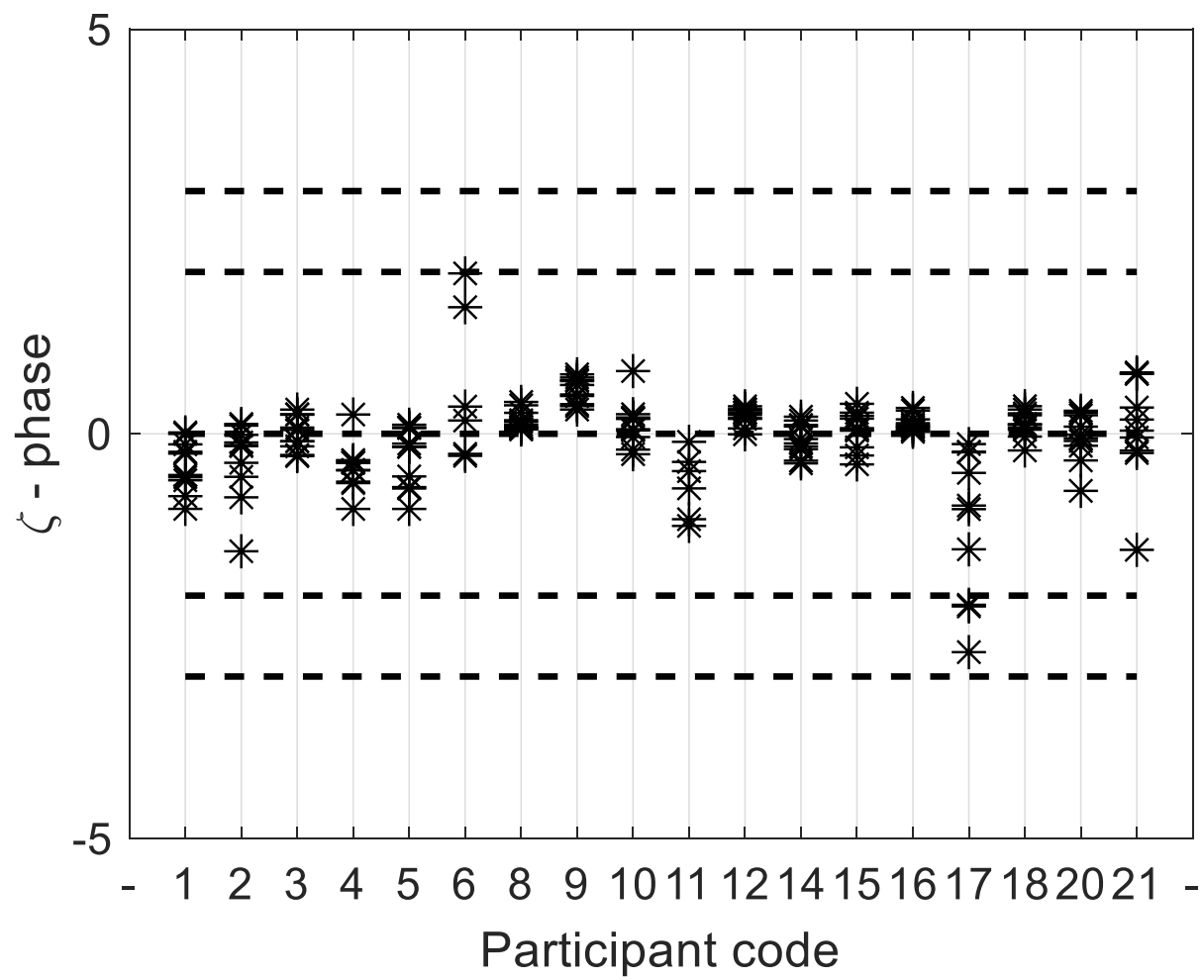

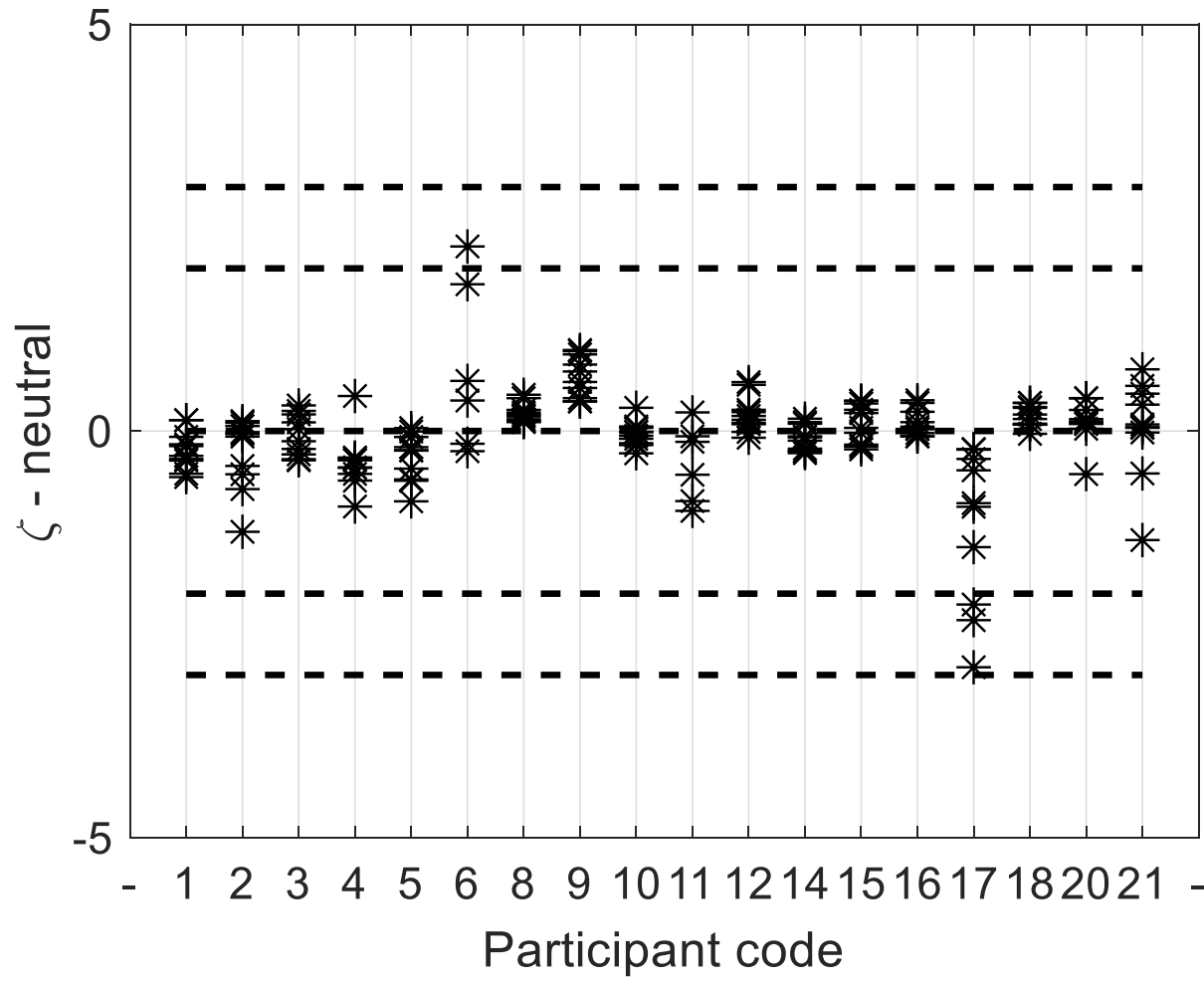

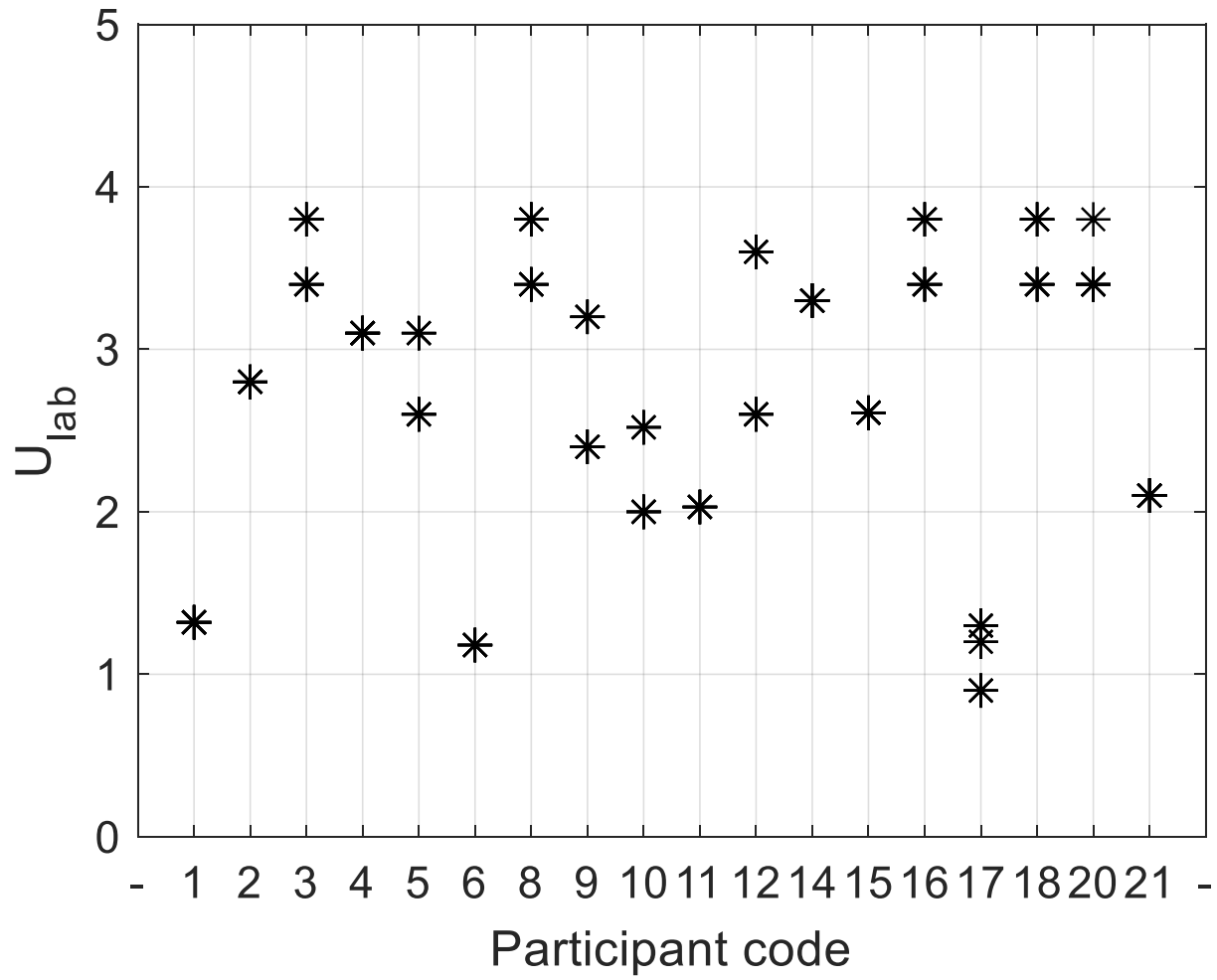

Ref. vales – comparison

f MHz	u dB	$X - x^*$ dB	s^* dB	z'
0.022	0.65	0.4	0.7	0.6
0.051	0.65	0.6	0.4	0.9
0.095	0.65	0.4	0.4	0.6
0.144	0.65	0.7	0.7	1.1
3.59	0.65	0.3	0.3	0.5
9.22	0.65	0.3	0.4	0.5
14.2	0.65	0.2	0.6	0.3
20.2	0.65	0.1	0.5	0.2
23.3	0.65	0.1	0.7	0.2
26.4	0.65	0.0	0.7	0.0

Remarks

- The reference values obtained from calibration of the Sample and from robust statistical analysis are compatible each other (maximum deviation 0.7 dB, over ten frequencies).
- The measurement results provided by the 18 participants at the 10 measurement frequencies selected by the Coordinator are within -2 dB to $+1.4$ dB from the reference values).
- 6 warning signals were detected over 344 measurement results (172 – phase, 172 – neutral).
- Standard measurement uncertainty declared by the laboratories comprised between nearly 0.45 dB and 1.9 dB, robust standard deviation s^* less than 0.7 dB.